

Double Cone Tumble Blender Specifications and Dimensions

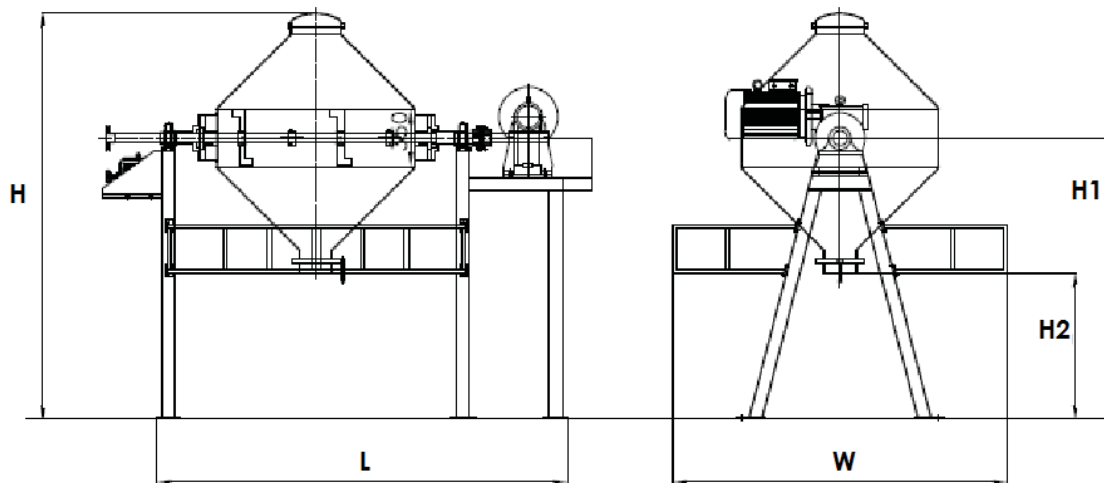

STANDARD FEATURES:

- Suitable for bulk densities up to 150 lb/cu.ft.
- Atmospheric design double cone vessel
- Stainless steel type 316 wetted parts
- 150-grit interior finish, 80-grit exterior finish
- Manually-operated butterfly discharge valve
- Hinged charging port
- Carbon steel safety railing with limit switches and A-frame support structure, painted with durable two-part epoxy coating
- TEFC motor designed for 230/460 volt, 3 phase, 60 Hz

AVAILABLE OPTIONS:

- Higher horsepower for handling higher bulk densities
- Full vacuum design
- Mirror finish
- All stainless steel construction
- Intensifier bar
- Explosion-proof or special voltage/frequency motor
- Jacketed vessel for heating and/or cooling
- Insulation and sheathing
- Control panel, explosion-proof operator station or PLC recipe controls

Model Number	Working Capacity		Full Holding Capacity		Standard HP	RPM	Dimensions (inches)				
	cu.ft.	liters	cu.ft.	liters			L	W	H	H1	H2
DCB-0.25	0.25	7	0.4	11	1	20	30	26	36	26	24
DCB-0.5	0.5	14	0.7	20	1	20	36	29	39	28	24
DCB-1	1	28	1.5	42	2	20	45	37	47	36	24
DCB-2.5	2.5	71	3.75	106	3	20	66	39	57	46	24
DCB-5	5	142	7.5	212	5	20	79	65	83	59	24
DCB-7.5	7.5	212	11	311	5	20	85	70	83	61	36
DCB-10	10	283	15	425	7.5	20	106	69	91	65	36
DCB-15	15	425	22	623	10	16	118	81	98	69	36
DCB-20	20	566	30	850	10	16	118	87	103	71	36
DCB-25	25	708	37	1048	10	16	126	91	110	77	36
DCB-30	30	850	45	1274	10	16	135	98	118	83	36
DCB-40	40	1133	60	1699	15	16	145	106	122	83	36
DCB-50	50	1416	75	2124	15	10	150	114	126	83	36
DCB-65	65	1841	97.5	2761	20	10	154	123	133	91	36
DCB-75	75	2124	112	3171	25	8	158	126	142	91	36
DCB-100	100	2832	150	4248	30	8	185	138	150	95	36



CHARLES ROSS & SON COMPANY

P.O. Box 12308, 710 Old Willets Path, Hauppauge, NY 11788

Telephone: 631-234-0500 • Fax: 631-234-0691

Website: www.mixers.com • E-mail: sales@mixers.com